

EVENT barrier

ASSEMBLY INSTRUCTIONS

June 2017 v2

- 1, Remove contents from packaging, check everything is present as per contents list.
- 2, Slide on a bracket top and bottom onto one of the uprights (95cm). (Fig 1)
- 3, Loosely place a clamp on the top of the upright, use this as a guide to position the top bracket sitting it directly under the clamp. Tighten the grub screw as indicated on the top bracket using the allen key provided, (Fig 2). Remove the clamp. Leave the bottom bracket loose as this will need to be adjusted later. Repeat for all the uprights
- 4, Insert the horizontal bars through the sleeves top and bottom on the banner. (Fig 3)
- 5, Lying the banner and bars flat, insert one end of the top bar all the way into the top bracket of the upright and tighten the grub screw indicated. (Fig 4) Repeat for the bottom bar.
- 6, Insert the other end of the horizontal bars into the brackets on the other upright, tightening the grub screws as indicated. (Fig 5)
- 7, Tension the banner by sliding the brackets down the upright, (Fig 6) measuring from the top to make sure that the banners are level. Secure by tightening the grub screw indicated. (Fig 7)
- 8, Move the bases roughly into their finished position and insert the spigots into the bases. (Fig 8)
When using a double spigot, ensure that it drops down into the hole with the small pin in the correct position allowing the spigot 'arm' to sit on top of the bung. (Fig 9)
- 12, Align the banner section and drop the banner unit onto the spigots. (Fig 10)
- 13, Re position the double clamp onto the uprights to secure together, tighten wingnut. (Fig 11)

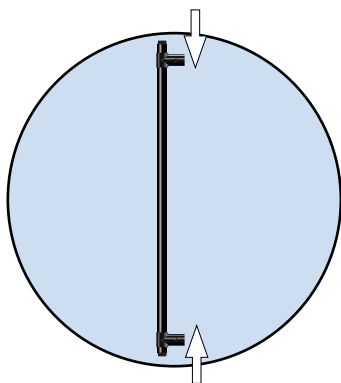

Fig 1

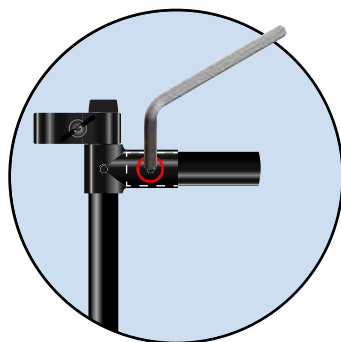

Fig 2

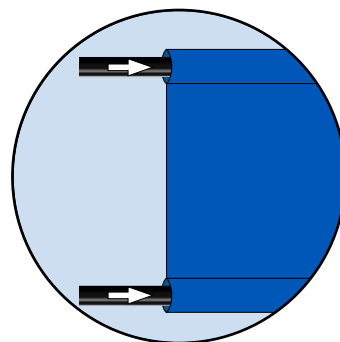

Fig 3

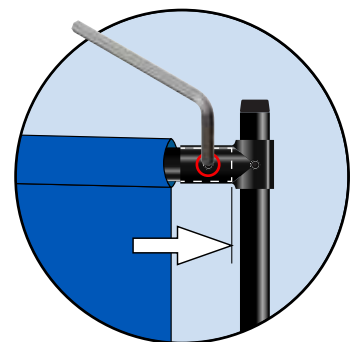

Fig 4

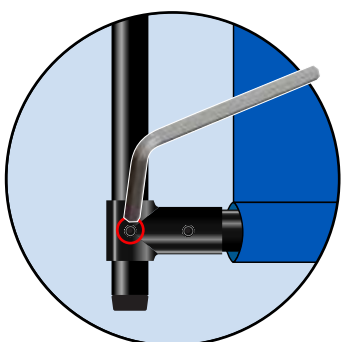

Fig 5

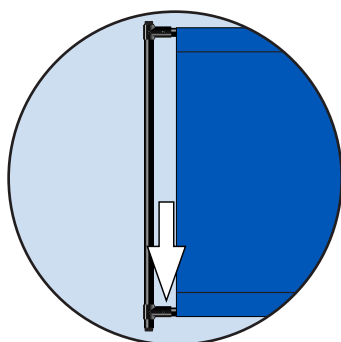

Fig 6

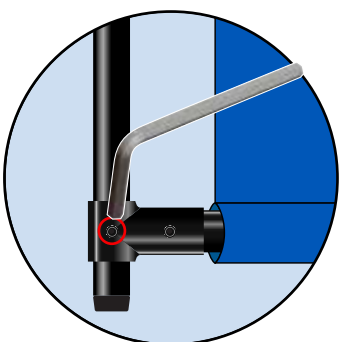

Fig 7

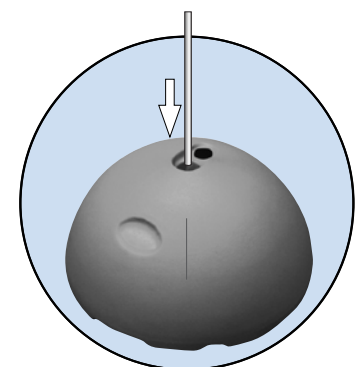

Fig 8

EVENT barrier

ASSEMBLY INSTRUCTIONS

June 2017 v2

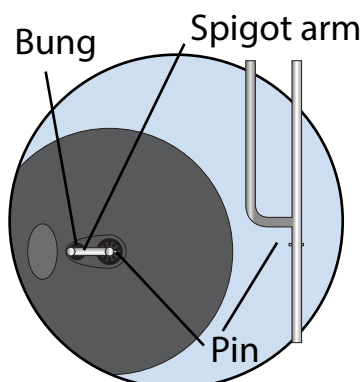

Fig 9

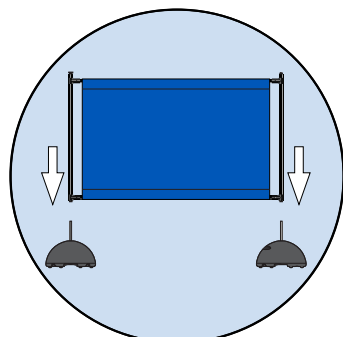

Fig 10

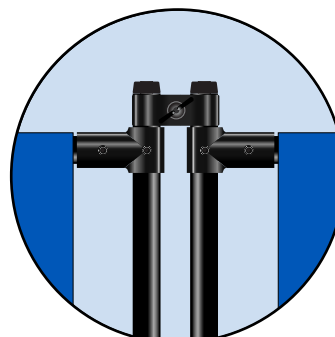
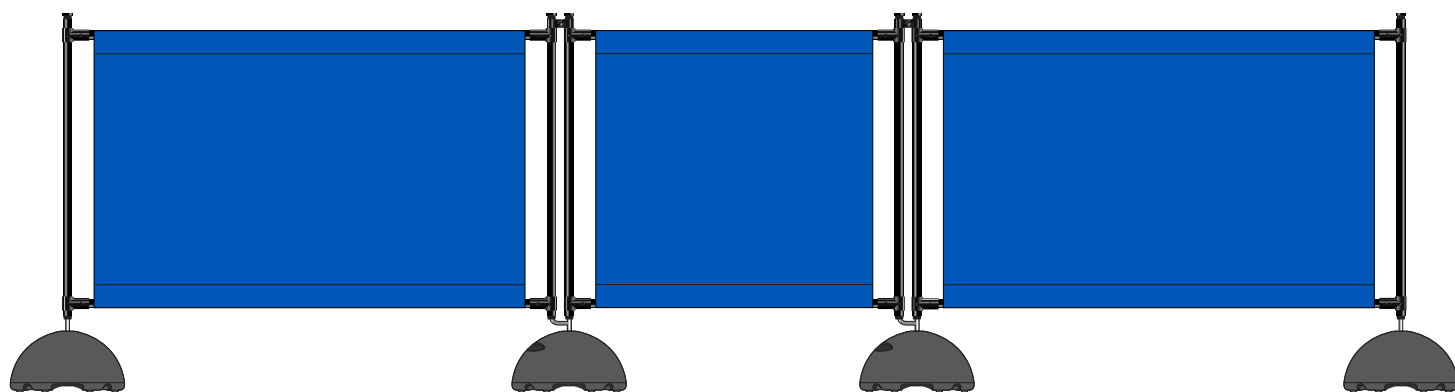

Fig 11



Barrier Specification

Horizontal bar length	1m	1.5m	2m
Horizontal Bar diameter	28mm	28mm	28mm
Upright Height	0.95m	0.95m	0.95m
Upright diameter	28mm	28mm	28mm
Banner size	90cm x 90cm	140cm x 90cm	190cm x 90cm
Base Size	37cm x 20cm	37cm x 20cm	37cm x 20cm
Base weight (sand)	18kg	18kg	18kg

CONTENTS

Qty of barriers	1	2	3	4	5
Horizontal bars	2	4	6	8	10
Brackets	4	8	12	16	20
Bases	2	3	4	5	6
Single Spigot	2	2	2	2	2
Double Spigot	n/a	1	2	3	4
Double Clamp	n/a	1	2	3	4
Cap Covers	2	4	6	8	10
Allen Key (per order)	1	1	1	1	1

WARNINGS

- Do not position the event barrier on uneven or loose surfaces, ensure all bases are level.
- Do not use the barriers in windy weather
- Do not sit, lean or stand on the event barriers as this may result in damage or personal injury
- During periods of inclement weather the arena barriers should be stored indoors.
- The fabric banner should be dry before storage